

R series

Polverizzatori semiportati

Trailed Sprayers

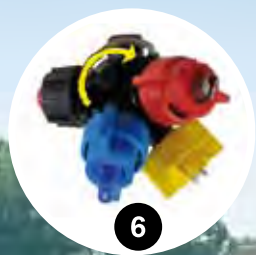

Campo R 32 con barra ALA621 21 metri
Campo R32 with boom ALA621 21 mt

I
GB

CAMPO

Polverizzatore trainato con capacità di 2400 e 3200 lt, pensato per un lavoro continuativo in grandi estensioni. Monta un parallelogramma ammortizzato con escursione di mm1600 e barre professionali verniciate o zincate a caldo da 18 a 24mt anche con geometria variabile per un trattamento veloce ed omogeneo. Equipaggiato con computer di spandimento Teejet 844 (foto 7) ed Oildrive (foto 8) per la movimentazione di ogni singola sezione barra con una comoda pulsantiera in cabina. Il premiscelatore Top Mix (foto 2) con regolatore di pressione indipendente consente di miscelare prodotto bypassando il regolatore di pressione principale in cabina.

Caratteristiche di serie Campo R (22 - 32)

- Telaio verniciato con piattaforma e scaletta
- Timone fisso ad occhione (foto 5)
- Cisterna principale 2400 e 3200 litri effettivi
- Cisterna lavaimpianto con lavabotte da 280 litri effettivi
- Cisterna lavamani da 15 litri
- Livello bagnato esterno
- Agitazione idraulica con tubo forato
- Deviatore 3 vie per riempimento
- Solubizzatore prodotto chimico al boccaporto
- Comandi da terra semplificati lato Sx (foto 4)
- Portaprodotti lato DX
- Premix Top con parallelogramma (foto 2)
- Mozzi 8 colonnette quadro 70 (22R) o 80 (32R)
- Assale regolabile in avanti e in larghezza (foto 3)
- Ruote 9.5 R44 (22R) o 11.2 R44 (32R)
- Oildrive 6 o 7 sezioni (foto 8)
- Attacco al trattore con 1 presa olio doppia (foto 9)
- Pompa membrana BP280 Desmopan
- Computer 844FG (foto 7)
- Controlli Barra/Acqua in cabina
- Sollevamento a parallelogramma ammortizzato 1600 mm (foto 1)
- Teejet con ugelli in ceramica (foto 6)
- Protezioni striscianti barra (foto 10)

Accessori principali

- Ruote 11.2R48 o 13.6 R48 per C22R-C32R
- Piede stazionamento idraulico (foto A)
- Freni pneumatici con freno stazionamento (foto B)
- Filtro galleggiante con tubo (foto C)
- Tracciafile con 5lt schiumogeno (foto D)
- Tracciafile satellitare GPS (foto E)

Trailed field sprayer with tank capacity of 2400 and 3200 litres, designed for continuous work in large areas.

The 'R' series is fitted with a shock absorbed parallelogram lifting with 1600mm stroke, and assemble a range of booms from 18 to 24mt, hot galvanized or painted, with variable geometry, for fast spraying operations. Equipped with Teejet 844 spraying computer (photo 7) and Oildrive (photo 8) for independent movement of each boom section by means of a control panel in cabin. The pre-mixer Top Mix (photo 2) with parallelogram lifting, is fitted with an independent pressure regulator which allows mixing in pressure without modifying pressure from the main regulator in cabin.

Main Features of CAMPO R series (22 - 32)

- Painted frame with platform and step
- Fix Draw Bar (pict. 5)
- 2400 or 3200 lt main tank capacity
- 280 lt washing circuit tank capacity
- 15 lt handwash tank capacity
- Outside water level
- Hydraulic agitation with drilled hose
- 3 ways diverter for fast filling
- Nozzle on Lid
- Easy water control on LH side (pict. 4)
- Product rack RH side
- Premix Top-Mix with parallelogram (pict. 2)
- 8 studs hubs with square 70 (22R) or 80 (32R)
- Axle adjustable (pict. 3)
- Tires 9.5 R44 (22R) or 11.2 R44 (32R)
- Oildrive 6 o 7 sections (pict. 8)
- One double oil tractor plug (foto 9)
- Comet Pump BP280 Desmopan
- Computer 844FG (pict. 7)
- Switch panel with all water/oil control in cabin
- Shock absorbed Parallelogram Lifting, stroke mm 1600 (pict. 1)
- Teejet jets with nr 3 sets of ceramic nozzle (pict. 6)
- Sliding protection for Boom (pict. 10)

Options and Accessories

- Tires 11.2R48 or 13.6 R48 for Campo R 22-32
- Hydraulic parking stand (pict. A)
- Pneumatic brakes with parking brake (pict. B)
- Filter with 6mt hose for filling (pict. C)
- Foam Marker with 5lt concentrated foam (pict. D)
- GPS Marker (pict. E)

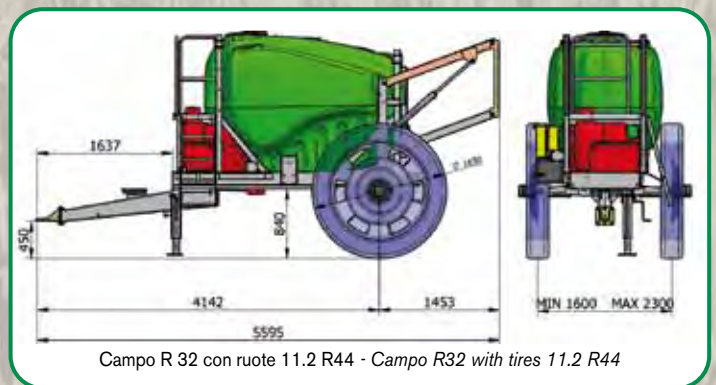
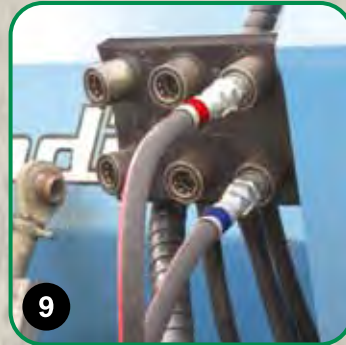

Optionals Campo R

